

GRID-CONNECTED PHOTOVOLTAIC POWER SYSTEM USING BOOST HALF- BRIDGE CONVERTER AND MPPT ALGORITHM

P. V. VIJAYA LAKSHMI¹, G. VENKATESWARLU² & P. S. RAJU³

¹M.Tech Student, Department of EEE, Narayana Engineering College, S.P.S.R. Nellore, Andhra Pradesh, India

²Professor, Department of EEE, Narayana Engineering College, Gudur, Andhra Pradesh, India

³Professor & HOD, Department of EEE, S.V. University, Tirupathi, Andhra Pradesh, India

ABSTRACT

Paper focuses on the power electronics used in the renewable energy systems especially in the photovoltaic applications. In recent years, interest in natural energy has grown in response to increased concern for the environment. Due to the limitations in the energy available from conventional sources, worldwide attention is being focused on renewable sources of energy. Especially, the energy obtained from solar arrays, becomes more and more important. In grid connected applications, a modular micro-inverter integrated with each photovoltaic (PV) panel can reduce the overall system cost and increase the system reliability and MPPT efficiency. In order to make the PV generation system more flexible and expandable, the backstage power circuit is composed of a high step-up converter and a pulse width-modulation (PWM) inverter. The traditional voltage-fed-full-bridge DC-DC converter suffers high cost, low transformer efficiency and discontinuous input current problems. A current-fed-half-bridge converter topology is utilized herewith continuous input current, low cost and high efficiency features. A single-phase PV micro inverter system with galvanic isolation is presented. By integrating micro inverter to each PV panel, localized MPPT of each individual PV panel can be achieved, thus leading to fast tracking speed and higher system efficiency.

KEYWORDS: PV Array, Boost, Half, Bridge, Grid, Connected Photovoltaic (PV) System, Maximum Power Point Tracking, Repetitive Current Control

I. INTRODUCTION

As a solution for the depletion of conventional fossil fuel energy sources and serious environmental problems, focus on the photovoltaic (PV) system has been increasing around the world. Grid connected solar energy technology is the fastest growing technology in the world today [1]-[3]. Grid connected converters are required to transfer green energy from solar system into the main grid. The first grid-connected inverters were. Based on Silicon Controlled Rectifiers (SCR) technology which was also limited in control and came with a high harmonic content which requires the use of bulky filters [3]. With the introduction of MOSFET for high power applications, the control of the grid connected inverters became more advanced.

In single phase grid connected photovoltaic power systems, the concept of micro inverter has become a future trend for its removal of energy yield mismatches among PV modules, possibility of individual PV module-oriented Optimal design, independent maximum power

Point tracking, and “plug and play” concept [4]-[5]. The low voltage solar output can be connected to the grid by using a converter with high step up ratio. Hence, a boost-half-bridge DC-DC converter cascaded by an inverter is the most popular topology, in which a HF transformer is often implemented within the DC-DC conversion stage. By replacing the

secondary half bridge with a diode voltage double, a new boost-half-bridge converter can be derived for unidirectional power Conversions [5]-[7]. The promising features such as low cost, high reliability and high efficiency, circuit simplicity can be obtained by use of the converter with minimal semiconductor devices. The repetitive current control technique is an effective solution for the elimination of periodic harmonic errors and has been previously investigated and validated in the un-interruptible power system, active power filters, boost-based PFC circuits, and grid-connected inverters/PWM rectifiers. In this paper, a plug-in repetitive current controller which is composed of a proportional part and an RC part is proposed to enhance the harmonic rejection capability [8].

The synchronized sinusoidal current can be injected to the grid by using a full bridge PWM inverter with an output LCL filter. Sinusoidal current with a unity power factor is supplied to the grid through a third-order LCL filter. In general, its performance is evaluated by the output current total harmonic distortions (THDs), power factor, and dynamic response [9]-[10]. The maximum Power Point (MPP) is the point in which maximum power is delivered from the solar cell to the PV system. MPPT is performed by the boost-half-bridge converter by using numerous MPPT techniques such as perturb and observe method, incremental conductance method,

Ripples correlation method, etc. In this proposed system, an optimal P&O method has been developed to limit the negative effect of the converter dynamic responses on the MPPT efficiency. A closed-loop control technique has been proposed to minimize the PV voltage oscillation [11]-[12].

The galvanic isolation is introduced on the DC side in the form of a high frequency DC-DC transformer. The pulse width modulation control is applied to both the dc-dc converter and the inverter. Constant voltage dc link decouples the power flow in the two stages such that the dc input is not affected by the double-line-frequency power ripple appearing at the ac side. The fast dynamic response is achieved during the transients of load. In order to reach an optimal efficiency of the boost-half-bridge converter, ZVS techniques can be considered for practical implementation [13]-[14]. The MPPT function block in a PV converter system increases the efficiency.

II. BOOST-HALF-BRIDGE PV MICROINVERTER

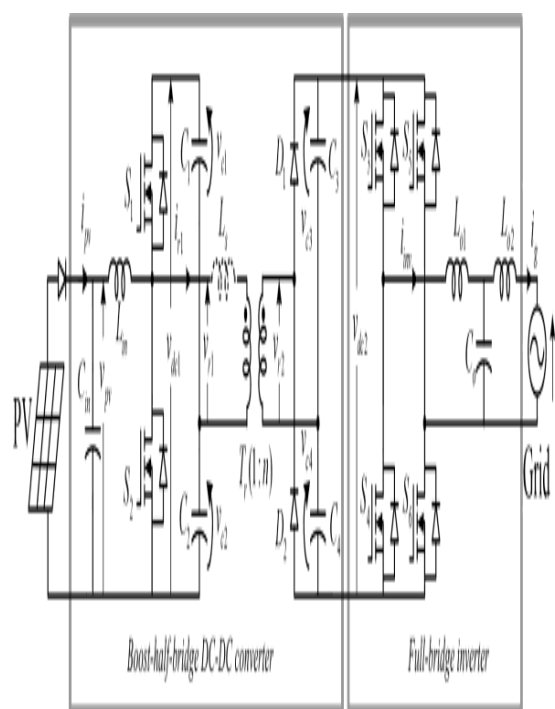

Figure 1: The Boost-Half-Bridge PV Micro Inverter Topology

high step-up ratio. The simple circuit topology with minimal use of semiconductor devices exhibits a low total cost and good reliability. In order to achieve fast dynamic responses of the grid current as well as the dc-link voltage, a current reference feed forward is added in correspondence to the input PV power.

Typically, the MPPT function block in a PV converter/inverter system periodically modifies the tracking reference of the PV voltage, or the PV current, or the modulation index, or the converter duty cycles. If the converter dynamics are disregarded in the MPPT control, undesirable transient responses such as LC oscillation, inrush current and magnetic saturation may take place. MPPT is performed by the boost-half-bridge DC-DC converter. An optimal P&O method has been developed to limit the negative effect of the converter dynamic responses on the MPPT efficiency. The closed-loop control technique has been proposed to minimize the PV voltage oscillation. However, the converter dynamic behavior associated with the MPPT operations can also influence the converter efficiency and functioning of the system. A customized MPPT producing ramp-changed PV voltage is then developed.

III. DESCRIPTION OF SYSTEM CONTROL

The boost half bridge PV micro inverter system is controlled by a digital approach. The PV voltage and current are both sensed for calculation of the instantaneous PV power, the PV power variation, and the PV Voltage variation. The MPPT function block generates a reference for the inner loop of the PV voltage regulation, which is performed by the dc-dc converter. At the inverter side, the grid voltage v_g is sensed to extract the instantaneous sinusoidal angle θ_g , which is commonly known as the phase lock loop. The inverter output current is pre-filtered by a first order low-pass filter on the sensing circuitry to eliminate the HF noises.

MPPT technique is used to extract maximum power in order to increase the efficiency of the system. The filter output is then fed back to the plug-in repetitive controller for the inner loop regulation. Either v_{dc1} or v_{dc2} can be sensed for the dc-link voltage regulation as the outer loop. In practice, the LVS dc-link voltage v_{dc1} is regulated for cost effectiveness. In order to achieve fast dynamic responses of the grid current as well as the dc-link voltage, a current reference feed forward is added in correspondence to the input PV power. The closed-loop control technique has been proposed to minimize the PV voltage oscillation.

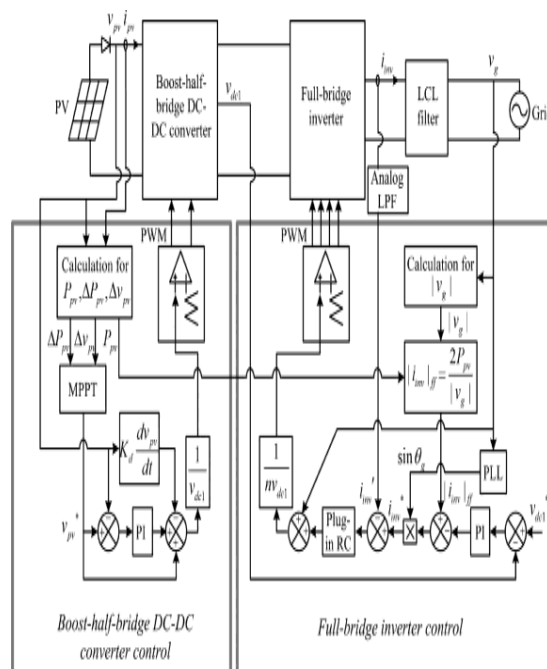

Figure 2: Architecture of the Proposed PV Micro Inverter System Control

VI. PLUG-IN REPETITIVE CURRENT CONTROLLER

Using an LCL filter in a grid-connected inverter system has been recognized as an attractive solution to reduce current harmonics around the switching frequency, improve the system dynamic response, and reduce the total size and cost. Typically, an undamped LCL filter exhibits a sharp LC resonance peak, which indicates a Potential stability issue for the current regulator design. Hence, either passive damping or active damping techniques can be adopted to attenuate the resonance peak below 0 dB. The current sensor is placed at the inverter side instead of the grid side.

V. BOOST-HALF-BRIDGE CONVERTER CONTROL

The PV voltage is regulated instantaneously to the command generated by the MPPT function block. High bandwidth proportional-integral control is adopted to track the voltage reference and to minimize double line- frequency disturbance from LVS dc link. The capacitor voltage differential feedback is introduced for active damping of the input LC resonance. Typically, the MPPT function block in a PV converter/inverter system periodically modifies the tracking reference of the PV voltage, or the PV current. In most cases, these periodic perturbations yield step change dynamic responses in power converters. The v_{C1} – v_{C4} is changing dynamically in accordance with $d1$. As a result, at any time, the charge and discharge rate of $C1$ – $C4$ must be limited such that the transformer flux is not saturated. For the sake of control simplicity and low cost, developing a customized MPPT method by carefully taking care of the boost-half-bridge converter dynamics.

Dynamics of the Boost-Half-Bridge Converter

The boost-half-bridge converter can be regarded as the integration of two sub circuit topologies: 1) The boost converter and 2) the half-bridge converter. The PV voltage regulator depicted in Figure 8 has ensured that both the steady state and the dynamic response of the boost converter part are taken care of. Hence, the following analysis will be only concentrated on the dynamics of the half-bridge converter part.

The major role of the half-bridge converter here is to transfer energy from the LVS dc link to the HVS dc link through the transformer. But besides that, it also allocates the amount of stored charges on the upper dc-link capacitors ($C1$ and $C3$) and the lower dc-link capacitors ($C2$ and $C4$) the effect of the transformer leakage inductance and power losses at this time, Figure 9 depicts the extracted half bridge converter part and its equivalent circuit seen from the LVS dc link. As v_{dc1} is regulated to a constant dc, the LVS dc link in Figure 9(b) is simply connected to a constant voltage source for approximation. $C3$ and $C4$ are both reflected to the transformer primary and combined with C_1 and C_2 . C_1' and C_2' stand for the equivalent dc-link capacitors, where $C_1' = C1 + n2C3$ and $C_2' = C2 + n2C4$. Lm , im , and λm denote the transformer primary magnetizing inductor, dc current, and dc flux linkage,

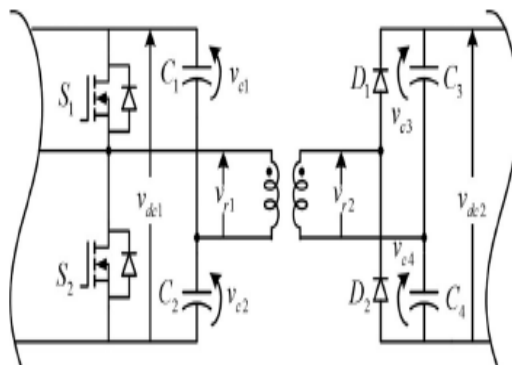

Figure 3: Half-Bridge Converter Part

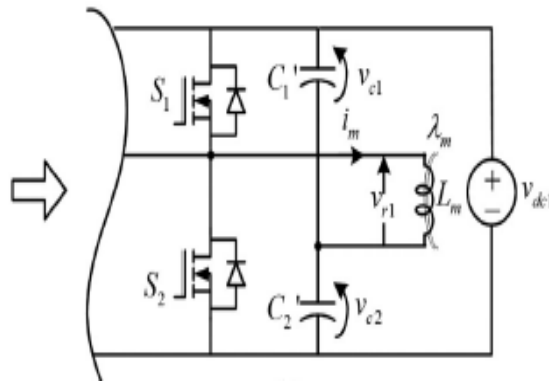

Figure 4: Equivalent Circuit Seen from the LVS Dc Link of (3)

VI. VARIABLE STEP SIZE MPPT ALGORITHM

For simplicity, it is assumed that the PV module is working under the standard irradiance (1000W/m) and the room temperature (25 °C). It is worth mentioning that some MPPT techniques calculate the step size online relying on the instantaneous values of ΔP_{PV} and Δv_{PV} in order to make the MPPT more adaptive. However, the sensed ΔP_{PV} and Δv_{PV} are vulnerable to noises, particularly, when they are small.

Therefore, an alternative method is adopted for robustness. Two points SPV1 and SPV2 on the dP/dip curve are selected to divide the PV operating points into three different zones. In zone 0, PV output power is close to the MPP, where a fine tracking step size is used to approach the exact MPP. In zones 1 and 2, a larger tracking step size is applied to boost up the tracking speed. The adopted MPPT algorithm is shown in Figure. The tracking step sizes in zones 0, 1, and 2 are represented by Δv_{ref0} , Δv_{ref1} , and Δv_{ref2} respectively. For the sake of control simplicity and low cost, developing a customized MPPT method by carefully taking care of the boost-half-bridge converter dynamics.

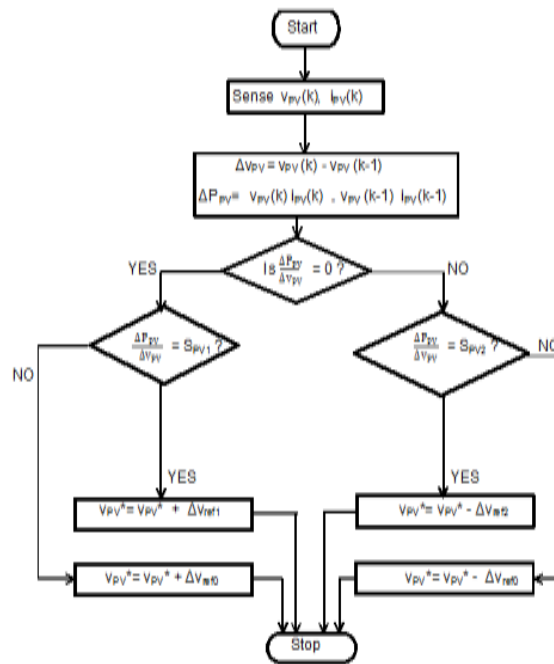

Figure 4: Flow Chart of the Variable Step-Size MPPT

VII. SIMULATION CIRCUIT DIAGRAM

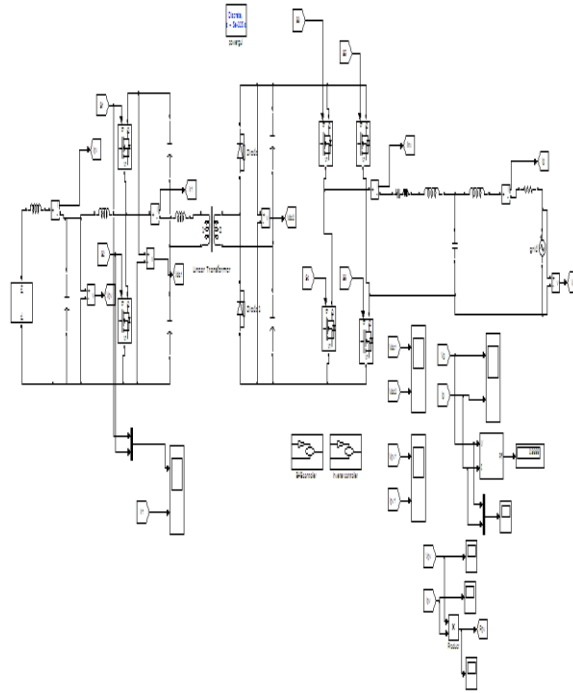

Figure 5: Simulation Model of the Proposed System

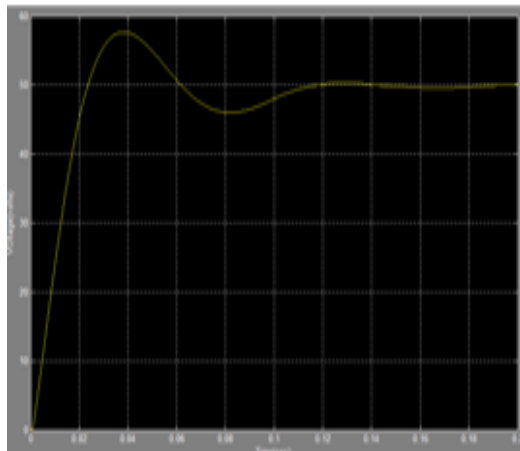

Figure 6: PV Cell Output Voltage

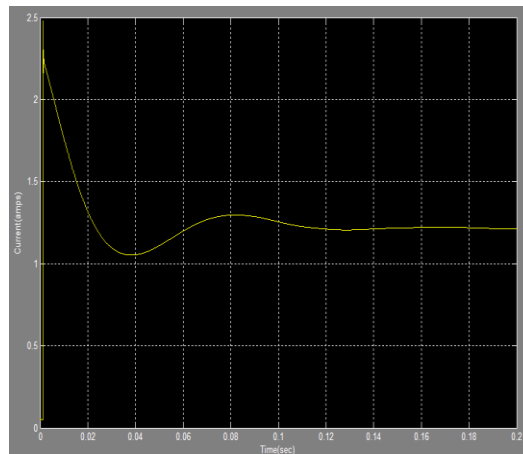

Figure 7: PV Cell Output Current

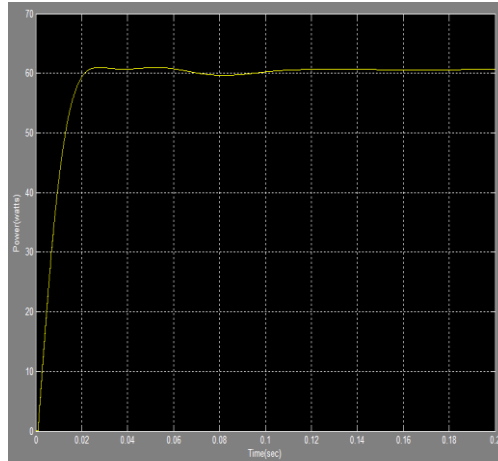

Figure 8: PV Cell Output Power

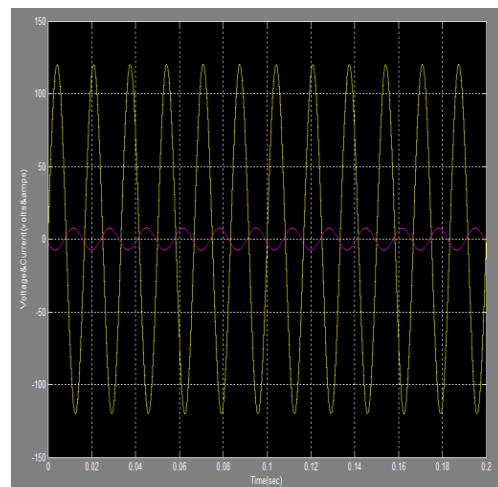

Figure 9: Steady State Grid Voltage and Current under Light Load Conduction

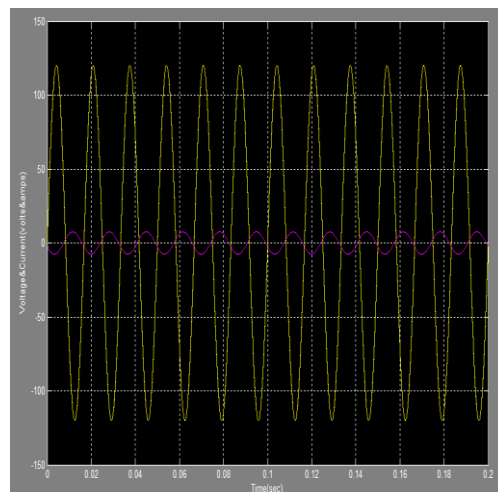

Figure 10: Steady State Grid Voltage and Current under Heavy Load Conduction

VIII. CONCLUSIONS

A boost-half-bridge micro inverter for grid-connected PV systems has been presented. The minimal use of semiconductor devices, circuit simplicity, and easy control, the boost-half-bridge PV micro inverter possesses features of low cost and high reliability. The boost-half-bridge dc–dc converter has a high efficiency (97.0%– 98.2%) over a wide operation range. And also the current injected to the grid is regulated precisely and stiffly. Under both heavy load and light load conditions, high power factor (>0.99) and low THD (0.9%–2.87%) are obtained.

The ramp-changed reference generated by the customized MPPT method for the PV voltage regulation guarantees a correct and reliable operation of the PV micro inverter system. Fast MPP tracking speed and a high MPPT efficiency (>98.7) is achieved by the variable step-size technique provides a correct and reliable operation of the PV micro inverter system.

REFERENCES

1. Yeong-Chau Kuo, Tsorng-Juu Liang and Jiann-Fuh Chen, "Novel Maximum-Power-Point-Tracking Controller for Photovoltaic Energy Conversion System," *IEEE Transactions on Industrial Electronics*, vol.48, no. 3, June 2001.
2. J. Kishore Kumar, V. Lakshmi Devi and H. Rajesh Kumar, "Design and Analysis of a Grid-Connected Photovoltaic Power System," *International Journal of Power System Operation and Energy Management*, ISSN (PRINT): 2231 – 4407, Volume-1, Issue-4, 2012.
3. Billy M. Ho and Henry Shu-Hung Chung, "An Integrated Inverter with Maximum Power Tracking for Grid-Connected PV Systems," *IEEE Transactions on Power Electronics*, vol. 20, no.4, July 2005.
4. Eftichios Koutroulis and Frede Blaabjerg, "Methods for Optimal Design of Grid Connected PV Inverters," *International Journal of Renewable Energy Research*, Vol.1, No.2, May 2011.
5. Prashant. V. Thakre, V. M. Deshmkh, and Saroj Rangnekar, "Performance Analysis of Photovoltaic PWM Inverter with Boost Converter for Different Carrier Frequencies Using MATLAB," *IACSIT International Journal of Engineering and Technology*, Vol. 4, No. 3, June 2012.
6. Suman Dwari and Leila Parsa, "An Efficient High-Step-Up Interleaved DC–DC Converter with a Common Active Clamp," *IEEE Transactions on Industrial Electronics*, vol.26, no.1, January 2011.
7. Tamer T.N. Khatib, Azah Mohamed and Nowshad Amin, "A New Controller Scheme for PhotovoltaicsPowerGeneration Systems," *European Journal of Scientific Research*, ISSN 1450-216X, Vol.33 No.3 (2009), pp.515-524.
8. CH.Sravan and D.Narasimha Rao, "An Interleaved Boost Converter with Zero-Voltage Transition for Grid Connected PV System,"
9. *International Journal of Emerging trends in Engineering and Development*, ISSN 2249-6149 Issue 2, Vol. 2, March-2012.
10. Soeren Baekhoej Kjaer, John K. Pedersen and Frede Blaabjerg, "A Review of Single-Phase Grid-Connected Inverters for Photovoltaic Modules," *IEEE Transactions on Industrial Electronics*, vol.41, no. 5, September 2005.
11. Nicola Femia, Giovanni Petrone and Giovanni Spagnuolo, "A Technique for Improving P&O MPPT Performances of Double-Stage Grid-Connected Photovoltaic Systems," *IEEE Transactions on Industrial Electronics*, vol.56.
12. Rong-Jong Wai and Wen-Hung Wang, "Grid-Connected Photovoltaic Generation System," *IEEE Transactions on Circuits and Systems*, vol. 55, no. 3, April 2008.
13. Nicola Femia, Giovanni Petrone and Giovanni Spagnuolo, "Optimization of Perturb and Observe Maximum Power Point Tracking Method," *IEEE Transactions on Power Electronics*, vol. 20, no.4, July 2005.

14. Quan Li and Peter Wolfs, "A Review of the Single Phase Photovoltaic Module Integrated Converter Topologies with Three Different DC Link Configurations," IEEE Transactions on Power Electronics, vol. 23, no. 3, May 2008.
15. D. Liu and H. Li, "A ZVS bi-directional DC–DC converter for multiple energy storage elements," IEEE Trans. Power Electron., vol. 21, no. 5, pp. 1513–1517, Sep. 2006.
16. C. Yoon, J. Kim, and S. Choi, "Multiphase DC–DC converters using a boost-half-bridge cell for high-voltage and high-power applications," IEEE Trans. Power Electron., vol. 26, no. 2, pp. 381–388, Feb. 2011.

AUTHOR'S DETAILS



G. VENKATESWARLU Has Received his B.Tech degree from J.N.T. University, Ananthapur. M.Tech degree with the Specialization of Electrical Power Engineering from J.N.T. University. At present he is working as an Associate Professor in Narayana Engineering college, Gudur. He had 5 years of experience in teaching field. He had published many papers in power system applications. Present he is interested in photo voltaic cell, facts controller, power system planning.



P. V. VIJAYA LAKSHMI Received The B. Tech Degree. From: P.B.R. Visvodaya Institute of Technology And Science 2010 Passed Out, Kavali. Affiliated To JNTU Ananthapur. Present She Perceive M.TECH from Narayana Engineering College, Nellore. Affiliated To JNTU Ananthapur Current Research Interested Area Power Systems and Solar Energies



Dr. P. SANGAMESWARA RAJU He is presently working as a Professor in SVU college of Engineering Tirupathi. Obtained his diploma and B. Tech in Electrical Engineering, M. Tech in power system operation and control and PhD in S.V. University, Tirupathi. His areas of interest are power system operation, planning and application of fuzzy logic to power system, application of power system like on linear controllers, on conventional Energy sources